



MBR1545CT/MBRB1545CT/MBR1545CT-1 SCHOTTKY RECTIFIER

Features

- 150 °C T_J operation
- Center tap configuration
- Low forward voltage drop
- High purity, high temperature epoxy encapsulation for enhanced mechanical strength and moisture resistance
- High frequency operation
- Guard ring for enhanced ruggedness and long term reliability
- Terminals finish: Tin Lead-free plated
- This is a Pb – Free Device
- All SMC parts are traceable to the wafer lot
- Additional testing can be offered upon request

Applications

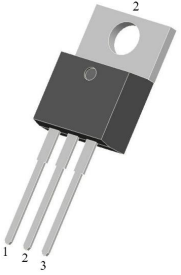
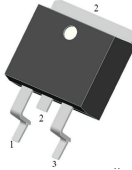
- Switching power supply
- Converters
- Free-Wheeling diodes
- Reverse battery protection

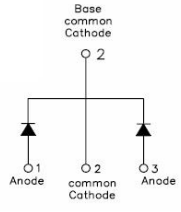
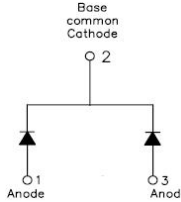
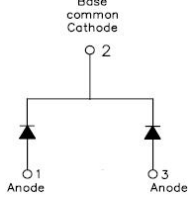
MBR1545CT	MBRB1545CT	MBR1545CT-1
		
		
TO-220AB	D ² PAK	TO-262

Maximum Ratings@T_c=25°C unless otherwise specified

Characteristics	Symbol	Condition	Max.	Units
Peak Repetitive Reverse Voltage	V _{RRM}	-	45	V
Working Peak Reverse Voltage	V _{RWM}			
DC Blocking Voltage	V _R			
Average Rectified Forward Current	I _{F(AV)}	50% duty cycle @T _c =125°C, rectangular wave form	7.5(Per Leg) 15(Per Device)	A
Peak One Cycle Non-Repetitive Surge Current(Per Leg)	I _{FSM}	8.3ms, Half Sine pulse	180	A

Electrical Characteristics:

Characteristics	Symbol	Condition	Typ.	Max.	Units
Forward Voltage Drop (Per Leg)*	V _{F1}	@ 15A, Pulse, T _J = 25 °C	0.70	0.84	V
	V _{F2}	@ 15A, Pulse, T _J = 125 °C	0.67	0.72	V
Reverse Current (Per Leg)*	I _{R1}	@V _R = rated V _R T _J = 25 °C	0.02	1.0	mA
	I _{R2}	@V _R = rated V _R T _J = 125 °C	12	15	mA
Junction Capacitance(Per Leg)	C _T	@V _R = 5V, T _C = 25 °C f _{SIG} = 1MHz	305	400	pF
Typical Series Inductance (Per Leg)	L _S	Measured lead to lead 5 mm from package body	8.0	-	nH
Voltage Rate of Change	dv/dt	-	-	10,000	V/μs

* Pulse width < 300 μs, duty cycle < 2%

Thermal-Mechanical Specifications:

Characteristics	Symbol	Condition	Specification	Units
Junction Temperature	T _J	-	-55 to +150	°C
Storage Temperature	T _{stg}	-	-55 to +150	°C
Typical Thermal Resistance Junction to Case(Per Leg)	R _{θJC}	DC operation	3.0	°C/W
Typical Thermal Resistance, Junction to Case(Per package)	R _{θJA}	DC operation	60	°C/W
Typical Thermal Resistance, Case to Heat Sink	R _{θCS}	Mounting surface, smooth and greased	0.50	°C/W
Case Style	TO-220AB D ² PAK TO-262			

Tube Specification

Device	Package	Weight	Shipping
MBR1545CT	TO-220AB	1.8g	50pcs / tube
MBRB1545CT	D ² PAK	1.85g	800pcs / reel
MBR1545CT-1	TO-262	1.85g	50pcs / tube

For information on tape and reel specifications, including part orientation and tape sizes, please refer to our tape and reel packaging specification.

Tube Specification(TO-220AB/TO-262)

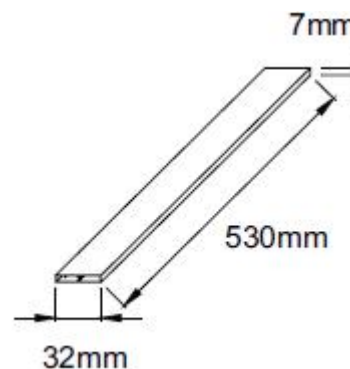

Ratings and Characteristics Curves

Figure 1 Typical Forward Characteristics

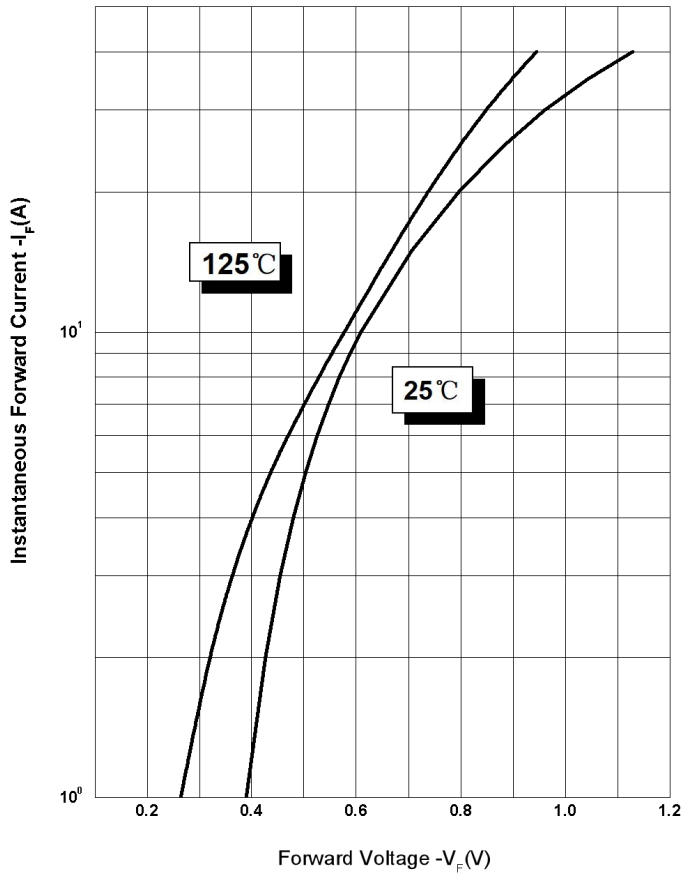

Figure 2 Typical Reverse Characteristics

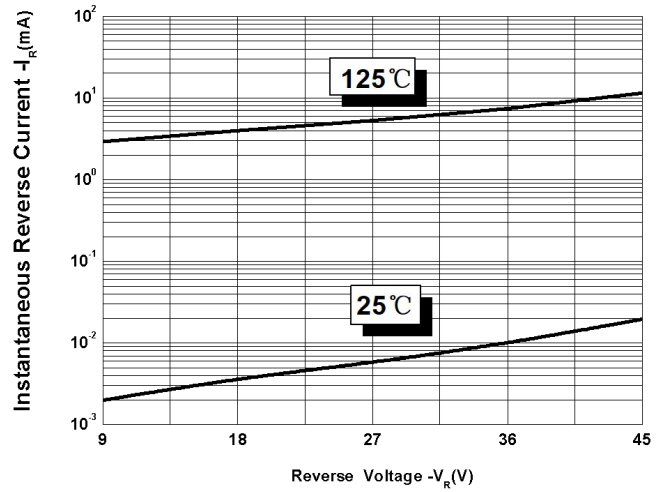
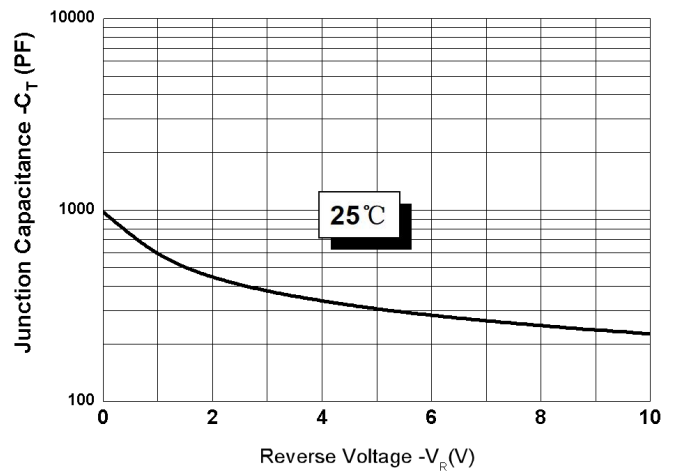
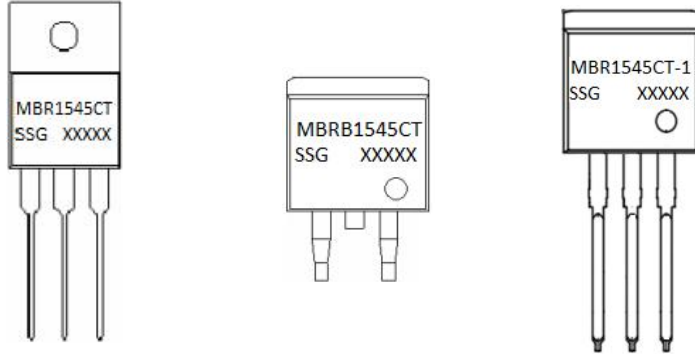

Figure 3 Typical Junction Capacitance



Marking Diagram



Where XXXXX is YYWWL

- MBR = Device Type
- B = Package type
- 15 = Forward Current (15A)
- 45 = Reverse Voltage (45V)
- CT -1 = Configuration
- SSG = SSG
- YY = Year
- WW = Week
- L = Lot Number

Cautions: Molding resin
 Epoxy resin UL:94V-0

Carrier Tape Specification D2PAK

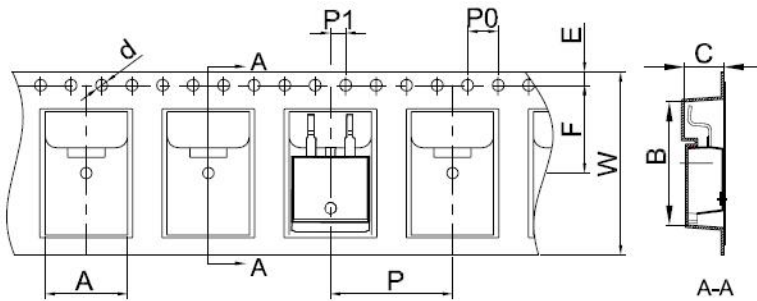

Symbol	Millimeters	
	Min.	Max.
A	10.70	10.90
B	16.03	16.23
C	5.11	5.31
d	1.45	1.65
E	1.65	1.85
F	11.40	11.60
P0	3.90	4.10
P	15.90	16.10
P1	1.90	2.10
W	23.90	24.30

Mechanical Dimensions TO-220AB

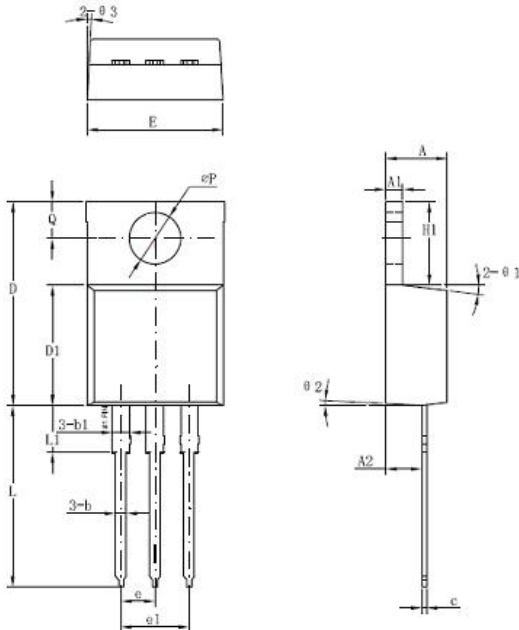

Symbol	Dimensions in millimeters		
	Min	Typical	Max
A	3.56	-	4.83
A1	0.51	-	1.4
A2	2.03	-	2.92
b	0.38	-	1.02
b1	1.14	-	1.78
c	0.31	-	0.61
D	14.22	-	16.51
D1	8.38	-	9.42
E	9.65	-	10.67
e	-	2.54	-
e1	-	5.08	-
H1	5.84	-	6.86
L	12.7	-	14.73
L1	-	-	6.35
ΦP	-	3.56	-
Q	2.54	-	3.43

Mechanical Dimensions D²PAK

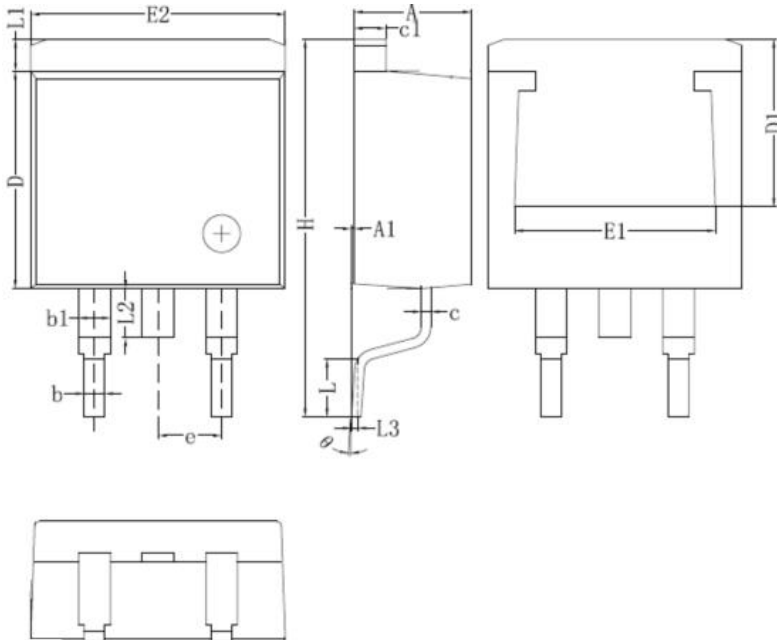

Symbol	Dimensions in millimeters	
	Min.	Max.
A	4.06	4.83
A1	0	0.26
b	0.51	0.99
b1	1.14	1.78
c	0.31	0.74
D	8.38	9.65
D1	6.4	
E1	6.22	
E2	9.65	10.67
e	2.54BSC	
H	14.6	15.88
L	1.78	2.8
L1	-	1.68
L2	-	2.2
L3	0.255BSC	
Θ	0	8°

Mechanical Dimensions TO-262

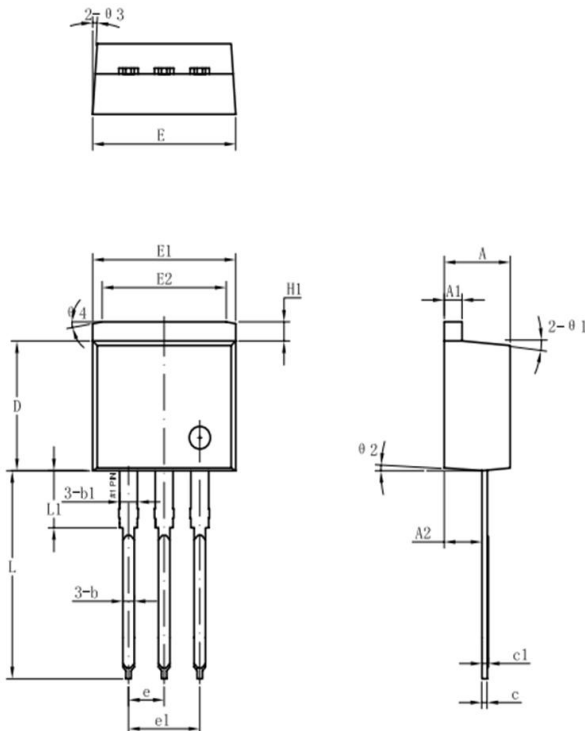

Symbol	Millimeters		
	Min.	Typical	Max.
A	4.55	4.70	4.85
A1	1.17	1.27	1.37
A2	2.59	2.69	2.89
B	1.22	1.37	1.47
b	0.71	0.81	0.96
b1		1.27	
c	0.36	0.38	0.61
D	8.55	8.70	8.85
E	10.01	10.16	10.31
E1	9.88	10.08	10.28
e		2.54	
e1		5.08	
H1	1.17	1.27	1.37
L	13.00	13.86	14.08
L1		3.8	
Θ1		5°	
Θ2		4°	
Θ3		4°	
Θ4		10°	



DISCLAIMER:

1- The information given herein, including the specifications and dimensions, is subject to change without prior notice to improve product characteristics. Before ordering, purchasers are advised to contact the SMC Diode Solutions sales department for the latest version of the datasheet(s).

2- In cases where extremely high reliability is required (such as use in nuclear power control, aerospace and aviation, traffic equipment, medical equipment, and safety equipment), safety should be ensured by using semiconductor devices that feature assured safety or by means of users' fail-safe precautions or other arrangement.

3- In no event shall SMC Diode Solutions be liable for any damages that may result from an accident or any other cause during operation of the user's units according to the datasheet(s). SMC Diode Solution assumes no responsibility for any intellectual property claims or any other problems that may result from applications of information, products or circuits described in the datasheets.

4- In no event shall SMC Diode Solutions be liable for any failure in a semiconductor device or any secondary damage resulting from use at a value exceeding the absolute maximum rating.

5- No license is granted by the datasheet(s) under any patents or other rights of any third party or SMC Diode Solutions.

6- The datasheet(s) may not be reproduced or duplicated, in any form, in whole or part, without the expressed written permission of SMC Diode Solutions.

7- The products (technologies) described in the datasheet(s) are not to be provided to any party whose purpose in their application will hinder maintenance of international peace and safety nor are they to be applied to that purpose by their direct purchasers or any third party. When exporting these products (technologies), the necessary procedures are to be taken in accordance with related laws and regulations..